



MODEL: CON1001-1

INSTALLATION AND OPERATION INSTRUCTIONS

This is a single functioning wireless remote control system for operating gas valves with ON/OFF latching solenoids

IF YOU CANNOT READ OR UNDERSTAND THESE INSTALLATION INSTRUCTIONS DO NOT ATTEMPT TO INSTALL OR OPERATE

INTRODUCTION

This remote control system was developed to provide a safe, reliable, and user-friendly remote control system for gas heating appliances. The system is operated manually from the transmitter. The system operates on radio frequencies (RF) within a 20-foot range using non-directional signals. The system operates on one of 255 security codes that are programmed into the transmitter at the factory; the remote receiver must learn the transmitter code prior to initial use.

TRANSMITTER

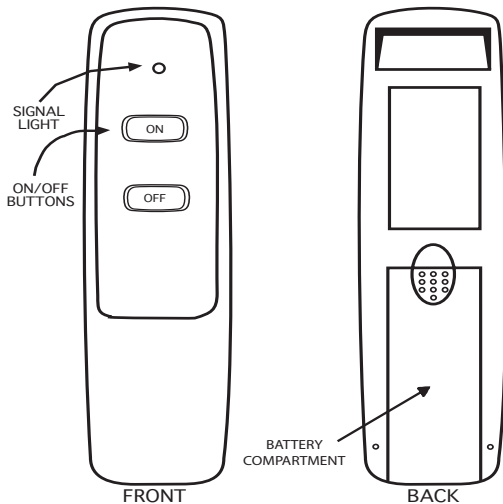

This remote control SYSTEM offers the user a battery-operated remote control to power a ON/OFF latching solenoid such as those used with gas valves used in some decorative gas logs, gas fireplaces and other gas heating appliances.

The circuit uses the battery power from the receiver to operate a latching solenoid. The circuit has reversing polarity software which reverses the positive (+) and negative (-) output of the receiver's battery power to drive solenoid (ON/OFF FLAME) or open/close. The SYSTEM is controlled by the remote transmitter.

The transmitter operates on a 12V battery made specifically for remote controls and electronic lighters. Before using the transmitter install the 12-volt (A-23) battery in the battery compartment.

It is recommended that ALKALINE batteries always be used for longer battery life and maximum operational performance.

The transmitter has ON and OFF functions that are activated by pressing either button on the face of the transmitter. When a button on the transmitter is pressed, a signal light on the transmitter illuminates to verify that a signal is being sent. Upon initial use, there may be a delay of three seconds before the remote receiver will respond to the transmitter. This is part of the system's design. If the signal light does not illuminate, check the position of the transmitter's battery.

POWER SETTING - CON 1001

The electronics in the remote control system have the capability of "powering" two different types of DC-powered components. If any operational problems accure contact Skytech Systems, Inc.

The RECEIVER comes from the factory programmed to provide pulse DC voltage (5.5) VDC to 6.3 VDC) to a latching solenoid.

REMOTE RECEIVER

THE REMOTE RECEIVER SHOULD BE PLACED WHERE AMBIENT TEMPERATURES DO NOT EXCEED 130°F.

The remote receiver (right) operates on four 1.5V AA-size batteries. It is recommended that ALKALINE batteries be used for longer battery life and maximum microprocessor performance. **IMPORTANT:** New or fully charged batteries are essential to proper operation of the remote receiver as a latching solenoid power consumption is substantially higher than standard remote control systems.

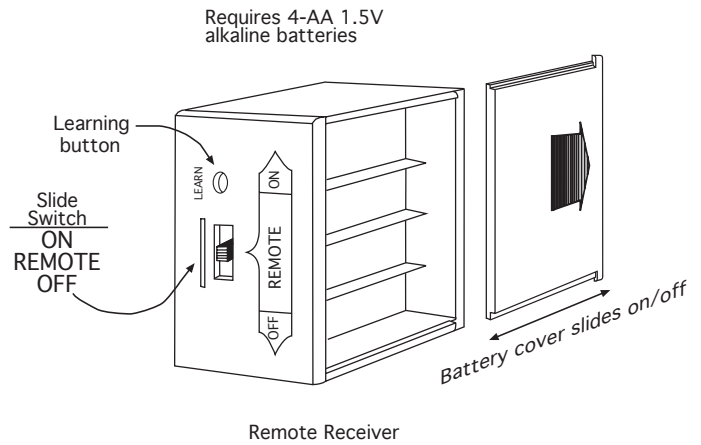

NOTE: The remote receiver will only respond to the transmitter when the 3-position slide button on the remote receiver is in the REMOTE position. The remote receiver houses the microprocessor that responds to commands from the transmitter to control system operation.

REMOTE RECEIVER FUNCTIONS

1. With the slide switch in the REMOTE position, the system will only operate if the remote receiver receives commands from the transmitter. Upon initial use or after an extended period of no use, the ON button may have to be pressed for up to three seconds before activating solenoid. If the system does not respond to the transmitter on initial use, see LEARNING TRANSMITTER TO RECEIVER.
2. With slide switch in the ON position you can manually turn ON the system without the transmitter.
3. With the slide in the OFF position, the system is OFF.
4. It is suggested that the slide switch be placed in the OFF position if you will be away from your home for an extended period of time. Placing the slide switch in the OFF position also functions as a safety "lock out" by both turning the system OFF and rendering the transmitter inoperative.

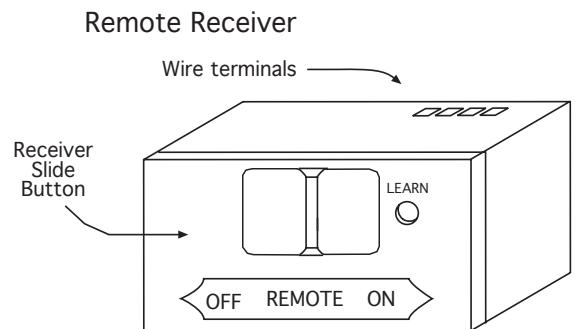

NOTE: This product is designed for use with an attended hearth appliance or fire feature. Adults must be present when the Control System is operating. **DO NOT** program or thermostatically set this Control to operate a hearth appliance or fire feature when Adults are not physically present. Furthermore, **DO NOT** leave the hearth appliance or fire feature burning unattended; it may cause damage or serious injury. If an Adult is going to be away from the hearth appliance or fire feature for any length of time, then the handheld/wall mount, receiver/control module and application should be in the "OFF" position.

INSTALLATION INSTRUCTIONS

WARNING
DO NOT CONNECT REMOTE RECEIVER DIRECTLY TO 110-120VAC POWER. THIS WILL BURN OUT THE RECEIVER. FOLLOW INSTRUCTIONS FROM MANUFACTURER OF GAS VALVE FOR CORRECT WIRING PROCEDURES. IMPROPER INSTALLATION OF ELECTRIC COMPONENTS CAN CAUSE DAMAGE TO GAS VALVE AND REMOTE RECEIVER.

The remote receiver can be mounted on or near the fireplace hearth. **PROTECTION FROM EXTREME HEAT IS VERY IMPORTANT.** Like any piece of electronic equipment, the remote receiver should be kept away from temperatures exceeding 130° F inside the receiver case. Battery life is also significantly shortened if batteries are exposed to high temperatures.

Make sure the remote receiver switch is in the OFF position before connecting wires. For best results it is recommended that 18 gauge stranded wires should be used to make connections and no longer than 20-feet.

WIRING INSTRUCTIONS

CONNECTING THE RECEIVER TO A VALVE WITH THE LATCHING SOLENOID

1. Connect the BLACK 18 gage stranded wire with the 1/4" female terminal from the receiver to the BLACK wire with the 1/4" male terminals from the valve solenoid.
2. Connect the RED 18 gage stranded wire with the 1/4" female terminal from the receiver to the RED wire with the 1/4" male terminals from the valve solenoid.
3. After receiver wires are connected to the valve solenoid wire make sure the receiver shield is located over the receiver and then locate the receiver in an area that will not exceed the 130°F.

IMPORTANT NOTE: Operation of these controls is dependent on which wire is attached to which terminal. If operation of control does not correspond to operating buttons on transmitter, reverse wire installation at the receiver or at control.

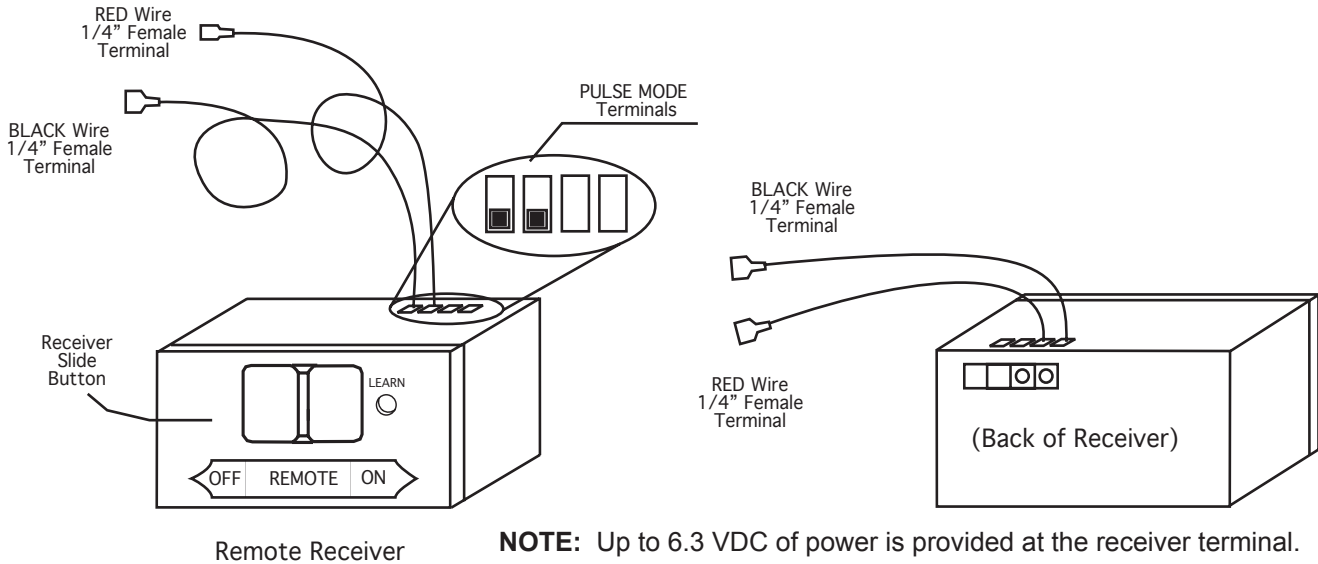

LEARNING TRANSMITTER TO RECEIVER

Each transmitter uses a unique security code. It will be necessary to press the LEARN button on the receiver to accept the transmitter security code upon initial use, if batteries are replaced, or if a replacement transmitter is purchased from your dealer or the factory. In order for the receiver to accept the transmitter security code, be sure the slide button on the receiver is in the REMOTE position; the receiver will not LEARN if the slide switch is in the ON or OFF position. The LEARN button is located on the front face of the receiver; inside the small hole labeled LEARN. Using a small screwdriver or end of a paperclip gently press and release the black LEARN button inside the hole. When you release the LEARN button the receiver will emit an audible "beep". After the receiver emits the beep press ANY transmitter button and release. The receiver will emit several beeps indicating that the transmitter's code has been accepted into the receiver.

The microprocessor that controls the security code matching procedure is controlled by a timing function. If you are unsuccessful in matching the security code on the first attempt, wait 1 - 2 minutes before trying again--this delay allows the microprocessor to reset its timer circuitry--and try up to two or three more times.

TRANSMITTER WALL CLIP

The transmitter can be hung on a wall using the clip provided. If the clip is installed on a solid wood wall, drill 1/8" pilot holes and install with the screws provided. If it is installed on a plaster/wallboard wall, first drill two 1/4" holes into the wall. Then use a hammer to tap in the two plastic wall anchors flush with the wall; then install the screws provided.

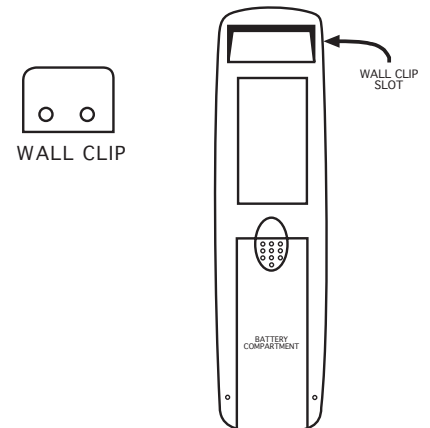

OPERATION

1. This remote control will operate the gas valves latching solenoid to open the gas flow to full ON.
2. When the ON button is depressed the transmitter sends a RF signal to the receiver. The receiver then sends a pulse of 6-volts of power to the solenoid. The solenoid then opens the gas flow to the burner then to full ON.
3. When the OFF button is depressed the transmitter sends a RF signal to the receiver. The receiver then sends a pulse of 6- volts of power to the solenoid. The solenoid then closes the gas flow to the burner then to full OFF.
4. The remote control will only work with the hand held transmitter. The receiver slide switch is only for positive OFF or REMOTE operation.

BATTERY LIFE

Life expectancy of the alkaline batteries in the CON-1001-1 can be up to 12 months depending on use of the solenoid function. Replace all batteries annually. When the transmitter no longer operates the remote receiver from a distance it did previously (i.e., the transmitter's range has decreased) or the remote receiver does not function at all, the batteries should be checked. It is important that the remote receiver batteries are fully charged, providing combined output voltage of at least 5.0 volts. The transmitter should operate with as little as 9.0 volts battery power. NOTE: Extensive use of the Solenoid will reduce the receiver's battery life significantly.

NOTE: Extensive use of the Latching Solenoid (ON/OFF) will reduce the receiver's battery life significantly.

TROUBLESHOOTING

If you encounter problems with your fireplace system, the problem may be with the fireplace itself or it could be with the CON-1001-1 remote system. Review the fireplace manufacturer's operation manual to make sure all connections are properly made. Then check the operation of the remote in the following manner:

1. Make sure the batteries are correctly installed in the RECEIVER. One reversed battery will keep receiver from operating properly.
2. Check battery in TRANSMITTER to ensure contacts are touching (+) and (-) ends of battery. Bend metal contacts in for tighter fit.
3. Be sure RECEIVER and TRANSMITTER is within 20 to 25-foot operating range.
4. Keep RECEIVER from temperatures exceeding 120° F. Battery life shortened when ambient temperatures are above 115° F.
5. If RECEIVER is installed in tightly enclosed metal surround, the operating distance will be shortened.
6. Clear Codes: Memory in the receiver might be full if the learn button is pressed too many times. If this happens it will not allow any more codes to be learned and no audible beep will be heard. To clear memory, place the receiver slide switch into the REMOTE position. Press the learn button and release after 10 seconds. You should hear three (3) long audible beeps indicating all codes have cleared. You can now "learn" the transmitter to the receiver as described in the General Information Section.

SPECIFICATIONS

BATTERIES: Transmitter 12V - (A23)
Remote Receiver 6V- 4 ea. AA 1.5 Alkaline
FCC ID No.'s: transmitter - K9L1001; receiver - K9L330IRX
Operating Frequency: 303.8 MHZ
Canadian ISC ID No.'s: transmitter - 2439 102 728; receiver – 2439A 3301RX

FCC REQUIREMENTS

NOTE: THE MANUFACTURER IS NOT RESPONSIBLE FOR ANY RADIO OR TV INTERFERENCE CAUSED BY UNAUTHORIZED MODIFICATIONS TO THE EQUIPMENT. SUCH MODIFICATIONS COULD VOID THE USER'S AUTHORITY TO OPERATE THE EQUIPMENT

For Technical Service, call:

U.S. INQUIRIES

(855) 498-8324 or (260) 459-1703
For Sales: (888) 672-8929
Web site: www.skytechpg.com

CANADIAN INQUIRIES

(877) 472-3923

MANUFACTURED EXCLUSIVELY FOR SKYTECH II, INC

LIMITED WARRANTY

1. **Limited Warranty.** Skytech II, Inc. ("Skytech") warrants that each new Skytech Control System, including all hardware, parts and components (the "System"), when used in accordance with the instructions furnished by Skytech provided with each System, shall be free in all material respects, of defects in materials and any workmanship under normal use, subject to proper installation ("Limited Warranty"). This Limited Warranty is non-transferrable and sets forth our sole and exclusive liability and the sole and exclusive remedies available in relationship to any non-conformity, defect or similar claim. This Limited Warranty only extends to the original retail purchaser of the System (the "Customer") and expires upon any sale or transfer of the home where the System is installed by the Customer.
2. **System Sold As Is.** Subject to this Warranty and any applicable state law, each System is sold by Skytech to a Customer on an "as is" basis. In addition, each System and Skytech's obligations are and remain subject to all additional disclaimers, limitations, reservations of rights, exclusions, and qualifications set forth on Skytech's website, www.skytechpg.com, all of which are considered part of the Warranty and are incorporated herein (collectively, the "Additional Terms"). Each Customer, by purchasing and/or using any System or any portion thereof, does so subject to the Warranty and the Additional Terms.
3. **Installation and Use of System.** Improper Installation, adjustment, alteration, service, or maintenance can cause property damage, personal injury, or loss of life. Thoroughly read the installation and operating instructions of this Control as well as the appliance it will be used in conjunction with as a system. If applicable, read the maintenance instructions before installing this control. This product is designed for use with an attended hearth appliance or fire feature. Adults must be present when the Control System is operating. DO NOT program or thermostatically set this Control to operate a hearth appliance or fire feature when Adults are not physically present. Furthermore, DO NOT leave the hearth appliance or fire feature burning unattended; it may cause damage or serious injury. If an Adult is going to be away from the hearth appliance or fire feature for any length of time, then the handheld/wall mount, receiver/control module and application should be in the "OFF" position.
4. **Repair or Replacement of System or Parts.** Should any System, or any hardware, components and/or parts contained therein fail due to a defect in workmanship or material provided by Skytech after the purchase of a System by a Customer, Skytech shall repair or, at its option, replace the defective System or part, hardware or component, subject to the Customer's compliance with all terms and conditions contained herein governing service and claims under the Warranty. Skytech shall provide replacement parts at no charge for the first (5) five years of this warranty, and at market cost for the Lifetime of the product to the original Customer. Gas valve and gas valve components will be available at no charge for one (1) year. If Skytech does not have the parts for an individual model, then a comparable replacement System will be provided at no charge within the first (5) five years after purchase, and then at market cost for the Lifetime of that product to the Customer.
5. **Warranty Claims; Skytech Service.** To submit a valid claim under the Warranty (each, a "Valid Claim"), a Customer must comply with the following:
 - a) Obtain a Return Material Authorization ("RMA") number from Skytech by calling (855) 498-8324; and
 - b) Provide written notice to a Skytech or an Authorized Dealer ("Dealer") and provide the Name, House Address, Email Address and Telephone Number of the Customer;
 - c) Describe the System model number and nature of the defect, nonconformity, or other problem with the System;
 - d) Provide such notice within thirty (30) days of discovery of such defect, nonconformity, or problem;
 - e) securely pack and ship the defective Skytech Product to Skytech II, Inc. ATTN: Warranty Department at 9230 Conservation Way, Fort Wayne, IN 46809. Customer assumes all costs and risks associated with transportation to Skytech (i) the RMA number is only valid for thirty (30) days from the date the RMA was issued, (ii) the RMA number should be clearly marked on the outside of each box being returned. Skytech may refuse shipments that DO NOT meet all of the Valid Claim requirements. Skytech is not responsible for any refused shipments or any damage caused due to shipping, whether or not it was a Valid Claim. Skytech shall be responsible for return shipment charges. Compliance with these requirements is a condition to coverage under this Limited Warranty.

Skytech may refuse any shipment(s) that does not meet all of the Valid Claim requirements. Skytech is not responsible for any refused shipments or any damage caused due to shipping, whether or not it was a Valid Claim. Skytech shall be responsible for reasonable return shipment charges for any Skytech System returned whether or not Skytech determines there is no defect with the System, reject for failure of the Customer to submit a Valid Claim, or otherwise determine is not eligible for service under the Warranty.

Upon receipt of a Valid Claim and the properly-returned System, Skytech shall, at its option, either (a) repair the System, at no charge to the Customer, or (b) replace the returned System with a new comparable System, at no charge to the Customer, or (c) provide the Customer with a refund in an amount equal to the price paid by the Customer for the defective System not including any service or labor cost associated with the installation or otherwise. Any System or

hardware, component or part repaired by Skytech hereunder, or any replacement System, hardware, component or part shall be shipped to the Customer by Skytech at Skytech's cost and the Warranty, the Additional Terms, and all other terms and conditions set forth herein shall extend to such repaired or replacement System, hardware, component or part. Skytech shall pay no refund before Skytech from the Customer receives the defective System, hardware, component and/or parts. Any obligation of Skytech under this Section 4 shall be and remain subject to Skytech's right to physically inspect the defective System, hardware, component and/or part returned to Skytech by the Customer. Some States do not allow the exclusion or limitation of incidental and consequential damages or limitation on how long an implied warranty lasts, so the above limitation may not apply to you. This warranty gives you specific rights and you may have other rights, which vary from state, province, or nation. To the extent allowable under any law, the liability of Skytech is limited to the express terms of this warranty, and Skytech expressly disclaims any and all implied warranties, including any warranties of fitness for a particular purpose or merchantability

REV. 2-24-17



Print information and detach at dotted line for return to: Skytech, ATTN WARRANTY DEPT., 9230 Conservation Way, Fort Wayne, IN 46809
Telephone: (855) 498-8324

Warranty Information

Purchase Date: _____ Model: _____ Date Code: _____

Purchased From: _____

Customer Name: _____ Phone: _____

Address: _____

Email Address: _____

City: _____ State/Prov. _____ Zip/Postal Code: _____

Back of remote Date Code Sample

16'	●	1	2	3	4	5	6
17'		7	8	9	10	●	12

1-12 is Month remote was produced
15-16 is Year remote was produced

Sample date code above is 1611

Please send a Proof of Purchase (original receipt) copy along with your Warranty form.

Santa's Helper

Exclusive offer to Skytech Remote Control Owners

This special offer is only provided to customers of Skytech that have purchased a remote control for their Hearth Product. This remote control system can be used for any 120VAC appliance, but perfect your Christmas Tree Lights or any other appliance that is difficult to reach or plug in. Simply plug the receiver into your wall outlet and your appliance into the receiver, push the ON button on the transmitter and you are in business. It's that easy!



The list price of **\$48.00** for the Santa's Helper has been cut almost in half to **\$20.00 USD** for this exclusive offer. Shipping and handling of **\$5.00 USD** should be added. Send us your check, money order or call us with your credit card number, along with the warranty information from your remote control of your Hearth Product. You can also send it via mail, fax, or e-mail.

Skytech Products Group
9230 Conservation Way
Fort Wayne, IN 46809
1-(888) 672-8929
1-(888) 672-8024 Fax
E-mail : order@skytechpg.com