

Comfort Control Retrofit

Instructions

Kits: 20301208, 20101209

Convert to SIT HI/LOW Control

The parts in this kit are intended to replace the Honeywell Comfort Control gas and ignition control system in the following fireplace insert models:

LHEC(20,30)RF(N,P)(Natural Vent)

LHECDV(20,30)RF(N,P)(Direct Vent)

CAUTION

Before installing this conversion kit:

- Disconnect electrical power to fireplace.
- Shut off gas supply.
- Shut off gas control valve.
- Allow unit to cool completely.
- Unplug fan cord from electrical outlet.

Kit contents:

SIT Gas Valve w/ Stepper Motor

Mounting Bracket for Valve #10006264

Ignitor, Piezo with Screw #057958

Bracket, Piezo Ignitor #52533

SIT Pilot Assembly

SIT Pilot Bracket #10004974

Valve Mounting Screws (4)

SIT ON/OFF Extension Knob #43D0094

Male Wire Connector #10007450

20308624, 20308625, 20308626 (transmitter, receiver
assy, batteries, wire harnesses, hardware)

Tools required: Adjustable Wrenches (2), Phillips
Screwdriver, Robertson Screwdriver, High Temperature
Silicone Sealant, Pipe Thread Sealant

This kit is to be installed only by a qualified service person familiar with the control system in accordance with these manufacturer's instructions and all applicable codes and requirements of the authority having jurisdiction. If the information in these instructions is not followed exactly, a fire, explosion or production of carbon monoxide may result causing property damage, personal injury or loss of life. The installation is not proper and complete until operation of the converted appliance is checked as specified in these manufacturer's instructions supplied with this kit.

Procedure

Remove glass door, logs and refractory panels if present. Be sure to note the location of each log or refer to fireplace Homeowner's Manual.

Remove the burner tray from the insert to complete the installation. Ensure gas line is shut off before disconnecting the inlet pipe from the valve.

Removal of Burner Tray

1. Disconnect fuel supply fitting from valve inlet fittings.
2. Unscrew the rear log bracket.
3. Disconnect any wires connected to the TH/TP, TP and TH valve terminals.

4. Remove the screws around the periphery of the burner tray. Carefully tilt the burner tray up. Remove the two (2) blower wires from the valve.

LHEC models only: Disconnect the spill switch wires. With all wires disconnected, the burner tray can be removed from the insert. Place the tray on a work surface.

5. **LHEC models only:** Unscrew the blower cover and disconnect wires from the blower motor. Remove the blower air channel and the strain relief holding the blower cord. Save the strain relief and discard the blower cord. *Figures 1 & 2*

6. **LHECDV models:** Disconnect cord wires from blower motor. Discard cord.



Installation of SIT System Components

1. **LHECDV models only:** Loosen or remove silicone sealant around pilot tubing and wiring where they pass through the burner tray.

All Models: Remove the existing pilot assembly and pilot bracket and discard both. Retain the pilot shield. Install new SIT pilot assembly, pilot bracket and the old shield.

LHECDV only: Reseal using silicone sealant where the thermocouple and wiring pass through the burner tray. *Figure 3* shows completed assembly.



Figure 3

KT1227

2. Disconnect manifold tube fitting from valve outlet fitting.
3. Disassemble and remove Honeywell valve and valve bracket. Remove inlet and outlet fitting from valve and clean threads on fittings for reuse. Discard valve and mounting screws.
4. Install new valve bracket. *Figure 4*

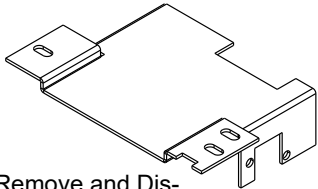

Remove and Discard this Bracket (Honeywell Valve)

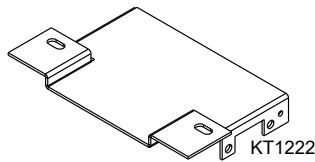

Install this Bracket (SIT Valve)

KT1222

Figure 4

5. Apply pipe thread sealant and install brass fittings into SIT valve inlet and outlet.
6. Using four (4) screws provided, install gas valve to bracket. **IMPORTANT: Make sure the gas valve is oriented properly. The valve outlet is on the same side as the terminal block.** *Figure 5*
7. Assemble manifold tube fitting to valve outlet fitting. Tighten securely.
8. Assemble fuel supply fitting to valve inlet fitting. Tighten securely.
9. Assemble new pilot thermocouple fitting to valve. Tighten fitting securely.

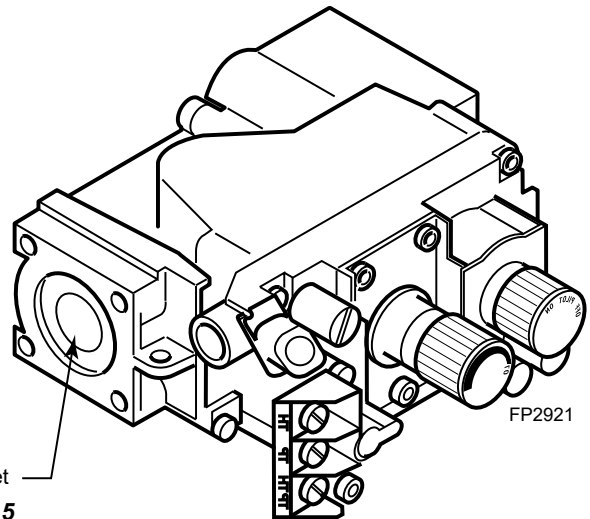

Figure 5

10. **LHECDV only:** Connect both pilot thermopile wires to valve terminal lower tabs TP and TP/TH.

LHEC only: Connect only one of the two thermopile wires to one of the terminals. With wire cutters cut off the connector on the remaining thermopile wire, strip back the wire and attach new male wire connector. Remove about 2" of the outer wire sheath. This will be connected to the spill switch wire when reinstalling the burner tray.

11. Locate supplied ignitor bracket with screw. The bracket mounts to the right front of valve, with an upward angle.
12. Remove the end nut from the piezo ignitor and install it to the front face of the bracket using the nut. Do not over tighten.
13. Attach wire from the pilot spark electrode firmly onto the push-on terminal at the rear tip of the piezo ignitor.
14. Attach ignitor and bracket to the right front of the valve with the supplied screw. Bracket should be mounted at an upward angle to avoid interference when reinstalling the burner tray.

To complete assembly of remaining components, refer to assembly instructions and warnings provided with RC-SITEA kit.

Reinstall Burner Tray

1. **LHEC models only:** Slide the new blower wires through the hole in the side of the blower air channel and connect to the blower through the opening in the rear of the insert. Reinstall the blower air channel. *Figure 6*. Pull the excess wire through the hole in the side of the channel and install the strain relief previously removed when taking the channel out.
2. **LHEC models only:** Install the blower cover. *Figure 7*
3. **LHEC models only:** Tilt the burner tray with the front down and the back up ready to complete the installation. *Figure 8*

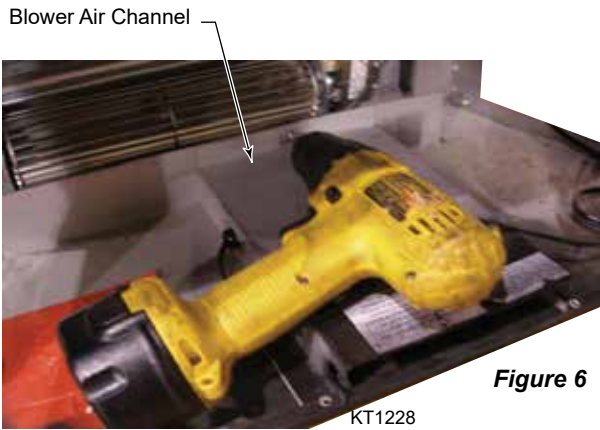

Figure 6



Figure 7



Figure 8

4. LHEC only: Connect the spill switch wires to the tray. Connect the thermopile wire with the male connector previously installed to the spill switch wire with the female connector. Complete the thermopile/spill switch circuit by connecting the other spill switch wire to the available TP or TH/TP terminal on the valve. *Figure 9*
5. Plug both the AC plug and the AC adapter from the receiver into the closest AC receptacle.

CAUTION: LHECDV only: Make sure all wires are clear of the fan blades. Use wire ties or retainers as necessary.

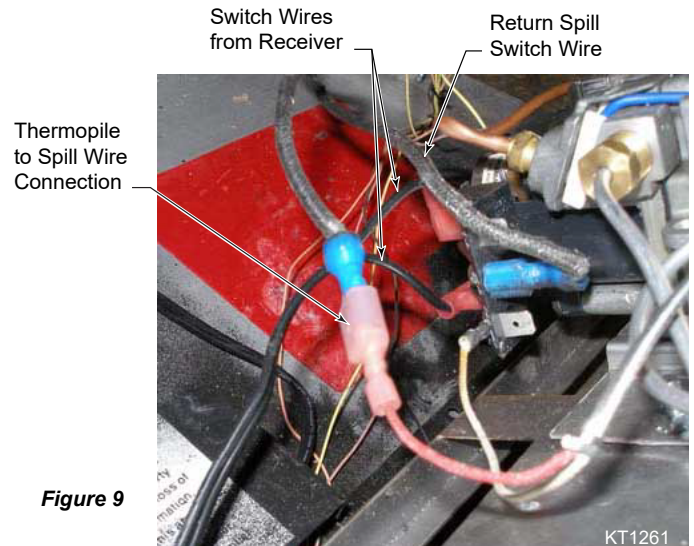

Figure 9

6. Apply the supplied velcro strip to the bottom of the receiver box and attach the box to a convenient location near the front of the fireplace. The receiver box fits best on the left side of the insert floor. *Figure 10*
7. Reinstall burner tray, embers, log brackets, pilot shield (if removed) and logs. Refer to Homeowner's Manual for proper log placement. For LHECDV, ensure the burner tray assembly gasket is installed and in good condition.



Figure 10

Leak Test

1. Turn fuel shut-off valve to ON.
2. Light pilot according to instructions provided.
3. Using a soap and water solution, check for and repair any detected leaks.

Refer to separate instructions provided with the RC-SITEA kit for information on remote control operation and troubleshooting.

Lighting and Operating Instructions

FOR YOUR SAFETY READ BEFORE LIGHTING

WARNING: If you do not follow these instructions exactly, a fire or explosion may result causing property damage, personal injury or loss of life.

- A. This heater has a pilot which must be lit manually. When lighting the pilot follow these instructions exactly.
- B. BEFORE LIGHTING smell all around the heater area for gas. Be sure to smell next to the floor because some gas is heavier than air and will settle on the floor.

WHAT TO DO IF YOU SMELL GAS

- Do not try to light any fireplace
- Do not touch any electric switch
- Do not use any phone in your building
- Immediately call your gas supplier from a neighbor's phone. Follow the gas supplier's instructions.

- If you cannot reach your gas supplier, call the Fire Department

- C. Use only your hand to push in or turn the gas control knob. Never use tools. If the knob will not push in or turn by hand, do not try to repair it, call a qualified service technician. Applying force or any attempted repair may result in a fire or explosion.
- D. Do not use this fireplace if any part has been under water. Immediately call a qualified service technician to inspect the heater and to replace any part of the control system and any gas control which has been under water.

Lighting Instructions

1. **STOP!** Read the safety information above.
2. Turn off all electrical power to the fireplace.
3. Open control access panel.
4. Push in gas control knob slightly and turn clockwise
↪ to "OFF".

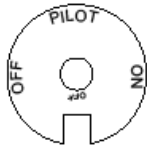

SIT NOVA

5. Wait five (5) minutes to clear out any gas. Then smell for gas, including near the floor. If you smell gas, STOP! Follow "B" in the safety information above. If you do not smell gas, go to the next step.
6. Remove glass door before lighting pilot.
7. Visibly locate pilot by the main burner.
8. Turn knob on gas control counterclockwise ↪ to "PILOT".

9. Push the control knob all the way in and hold. Immediately light the pilot by repeatedly depressing the piezo spark ignitor until a flame appears. Continue to hold the control knob in for about one (1) minute after the pilot is lit. Release knob and it will pop back up. Pilot should remain lit. If it goes out, repeat steps 5 through 8.

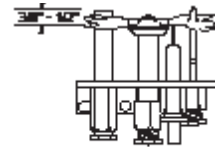

- If knob does not pop up when released, stop and immediately call your service technician or gas supplier.
 - If after several tries, the pilot will not stay lit, turn the gas control knob to "OFF" and call your service technician or gas supplier.
10. Replace glass door.
 11. Turn gas control knob to "ON" position.
 12. Turn on all electrical power to the fireplace.

To Turn Off Gas To Heater

1. Turn the On/Off switch to Off position or set the thermostat to lowest setting.
2. Turn off all electric power to the fireplace if service is to be performed.
3. Open louvre assembly bottom.
4. Push in gas control knob slightly and turn clockwise ↪ to "OFF". Do not force.
5. Close control access panel.

Hearth & Home Technologies
7571 215th Street West, Lakeville, MN 50044
www.hearthhome.com